

# Einbauanleitung

## Mounting instruction

### Montagehandleiding

### Instructions de montage

### Istruzioni di montaggio

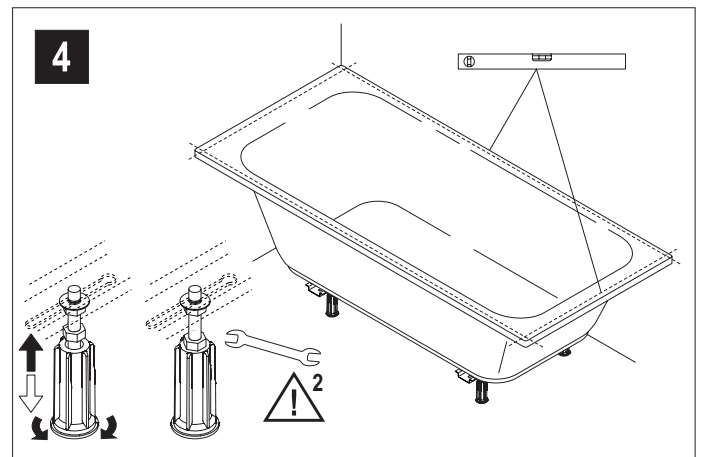
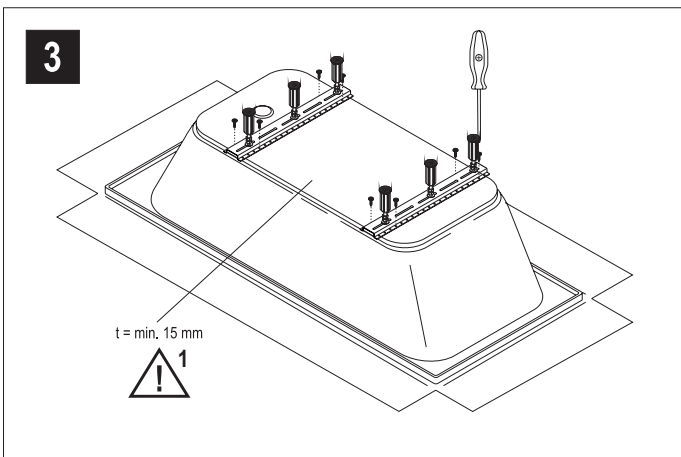
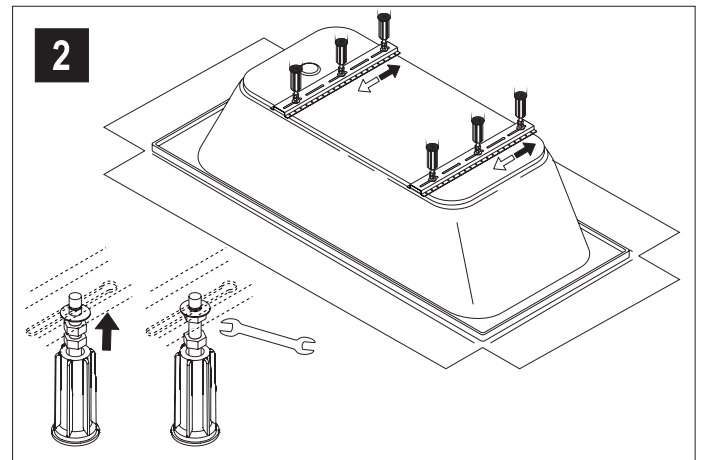
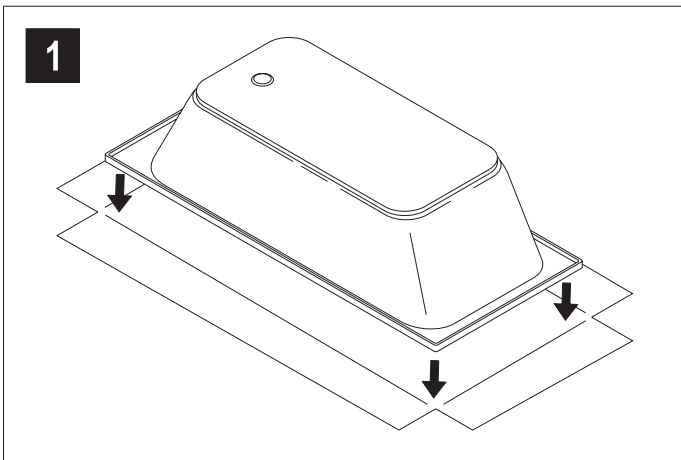
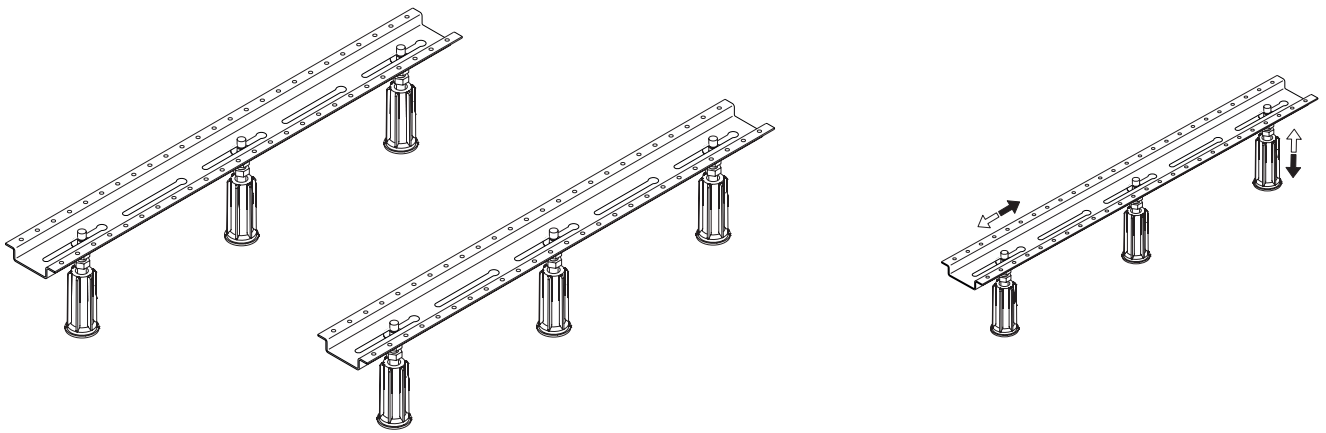

**Einbauanleitung**  
**Mounting instruction**  
**Montagehandleiding**  
**Instructions de montage**  
**Istruzioni di montaggio**

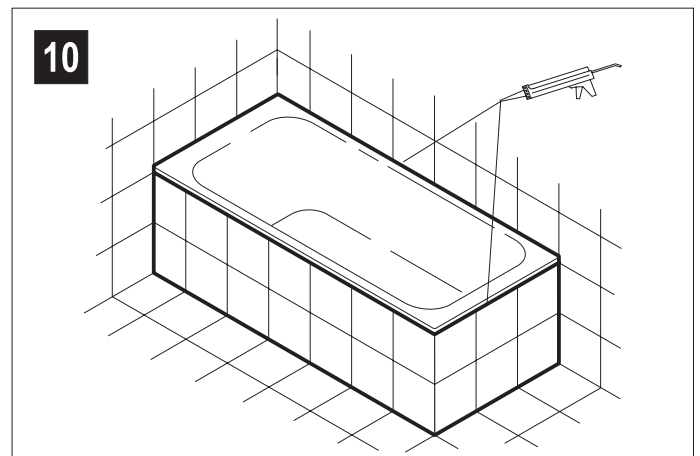
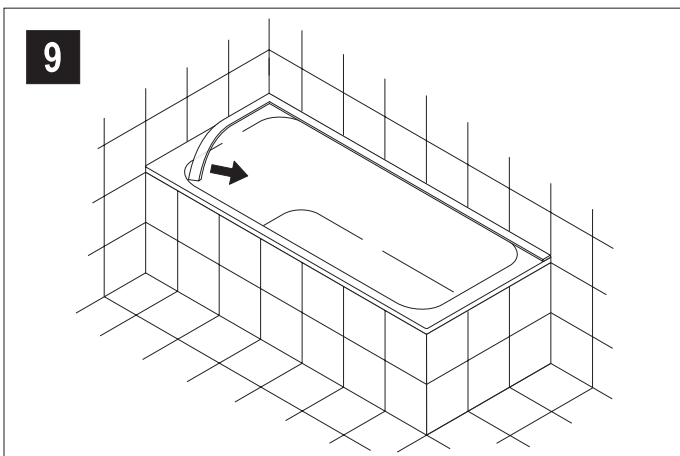
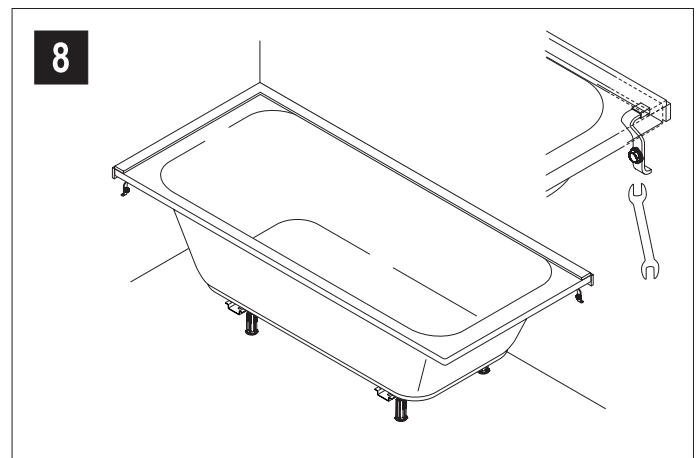
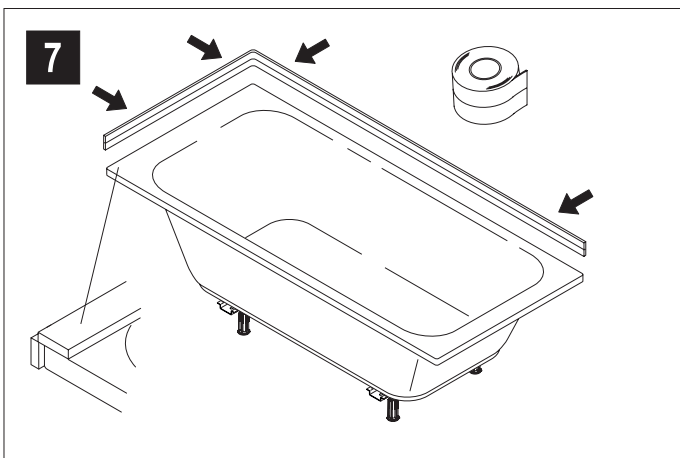
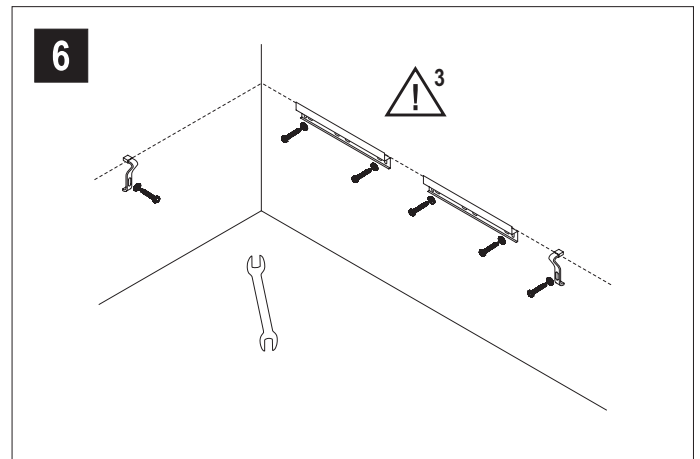
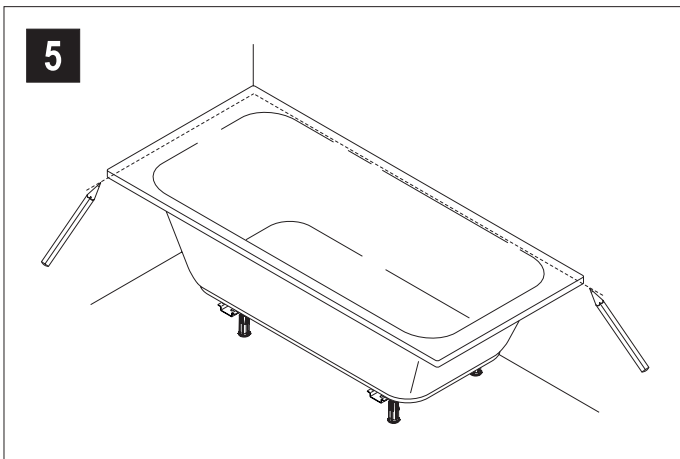

# Einbauanleitung

## Mounting instruction

### Montagehandleiding





### Instructions de montage

### Istruzioni di montaggio

---





#### Verwendung:

- Für den Einbau muss ein ebener, tragfähiger, schwingungsfreier Untergrund vorhanden sein.
- Für Acrylbadewannen bis 2000 × 900 mm

-  Die einschlägigen Verarbeitungsrichtlinien aller beteiligten Gewerke sind zu berücksichtigen.
-  1 Die Schraubenlänge ist zu beachten. Der Wannenerboden muss mindestens 15 mm stark sein.
-  2 Nach dem Ausrichten der Badewanne die höhenverstellbaren Füße mit der Sechskantmutter gegen erneutes Verstellen sichern.
-  3 2 Wannenerandklemmstücke + 2 Wannenerandklemmleisten/Wannenerandauflegeleisten.





#### Use:

- For installation, a flat, firm, vibration-free foundation is required.
- For acryl bath tubs up to 2000 × 900 mm

-  The relevant processing guidelines of all trades involved are to be considered.
-  1 The screw length has to be observed. The tray bottom should be at least 15 mm thick.
-  2 After alignment of the bath tub, lock the height-adjustable feet by the hexagon nut against misadjustment.
-  3 2 tub rim clamping pieces + 2 tub rim clamping strips/tub rim supporting strips





#### Toepassing:

- Voor de montage moet een vlakke, stevige, trillingsvrije ondergrond aanwezig zijn.
- Voor acryl badkuipen tot 2000 × 900 mm

-  De relevante verwerkingsrichtlijnen voor alle betrokken gespecialiseerde werkzaamheden dienen in acht te worden genomen.
-  1 De schroeflengte moet worden in acht genomen. De vloer onder de bak moet tenminste 15 mm dik zijn.
-  2 Na het uitlijnen van de badkuip moeten de in hoogte verstelbare pootjes met de zeskantmoer tegen opnieuw verstellen worden geborgd.
-  3 2 bakrandklemstukken + 2 bakrandklemstrippen/bakranddraagstrippen





#### Utilisation:

- Pour l'installation, il faut une surface plate, portante et sans vibration.
- Pour baignoires en acrylique jusqu'à 2000 × 900 mm

-  Les directives de traitement en vigueur pour tous les corps de métiers engagés doivent être respectées.
-  1 La longueur de la vis doit être respecté. Le fond du bac doit avoir au moins 15 m d'épaisseur.
-  2 Après le dressage de la baignoire, bloquer les pieds réglables en hauteur avec l'écrou hexagonal pour éviter tout dérèglement.
-  3 2 crochets fixation de baguette d'appui + 2 baguettes de blocage/baguettes d'appui de bordure de bac

#### Utilizzo:

- Per il montaggio deve essere presente una superficie di appoggio piana, di portata sufficiente e senza vibrazioni.
- Per vasca da bagno in acrilico fino a 2000 × 900 mm

-  È necessario osservare le direttive specifiche di lavorazione di tutti i sistemi interessati
-  1 La lunghezza di vite deve essere osservata. Il sottofondo della vasca deve essere spesso almeno 15 mm.
-  2 Dopo aver posizionato la vasca da bagno, bloccare i piedi di appoggio regolabili in altezza con i dadi esagonali per impedire che si spostino.
-  3 2 elementi di bloccaggio del bordo della vasca + 2 listelli di bloccaggio per il bordo della vasca/listello di appoggio per il bordo della vasca

# Einbauanleitung

## Mounting instruction

### Montagehandleiding

### Instructions de montage

### Istruzioni di montaggio

---

Empfohlenes Zubehör / Recommended accessories /  
Aanbevolen toebehoren / Accessoires recommandés /  
Accessori raccomandati:

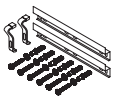

Wannenrandklemmleisten  
Tray rim clamping strips  
Bakrandklemstrips  
Baguettes de blocage bordure de bac  
Listelli di bloccaggio per il bordo della vasca

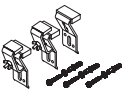

Wannenrandklemmstück  
Tray rim clamping piece  
Bakrandklemstuk



Crochets fixation de baguette d'appui  
Elemento di bloccaggio del bordo della vasca



Zur Körperschallentkopplung von Stahl- und Acrylwan-  
nen zur Wand  
For acoustic decoupling of steel and acrylic trays from  
the wall  
voor geluidsisolatie van stalen en acryl bakken t.o.v. de  
muur  
Pour l'isolation phonique des bacs en acier et en acry-  
lique contre le mur  
Per il disaccoppiamento acustico tra vasche in acciaio  
ed in acrilico e la parete



Zur Körperschallentkopplung von Stahl- und Acrylwan-  
nen zur Ab-/Ummauerung  
For acoustic decoupling of steel and acrylic trays from  
the lining/surround  
Voor geluidsisolatie van stalen en acryl bakken t.o.v. de  
ombouw  
Pour l'isolation phonique des bacs en acier et en acry-  
lique contre le muret de pourtour  
Per il disaccoppiamento acustico tra vasche in acciaio  
ed in acrilico e la muratura sottostante/perimetrale

---